

# PRPD120 Gasoline Pile Driver



CE

**PREDATOR**  
POWER PRODUCTS

# User Manual

The pile driver is designed for ease of operation and maintenance, offering a long service life. It is a preferred choice for customers due to its reliability. For your safety, please read this manual carefully before using the machine to prevent physical injury or mechanical damage.

## Contents

1. Name of Main Parts .....	3
2. Description of Safe Operation.....	4
3. Main Use and Function.....	4
4. Preparation before Use.....	5
5. Starting .....	6
6. Operation .....	7
7. Turning off the Machine .....	7
8. Technical Maintenance .....	8
9. Failure Analysis and Its Eliminating Methods .....	11
10. Key Data of Product .....	12
11. Declaration of Conformity .....	12
12. Maintenance Cycle.....	13
13. Parts List and Exploded View of PRPD120 Pile Driver .....	14
14. Parts List and Exploded View of 140FA.....	16

## 1. Name of Main Parts (4-stroke engine & Honda GX35 engine)

No.	Name of Part	No.	Name of Part	No.	Name of Part
1	Air filter	2	Fuel can lid	3	Fuel can
4	Throttle button	5	Throttle cable	6	Damping spring
7	Muffler	8	Oil filler cap	9	Lubrication indicator
10	Grip	11	Front placket	12	120mm adapter
13	Gear cover	14	Stop switch		

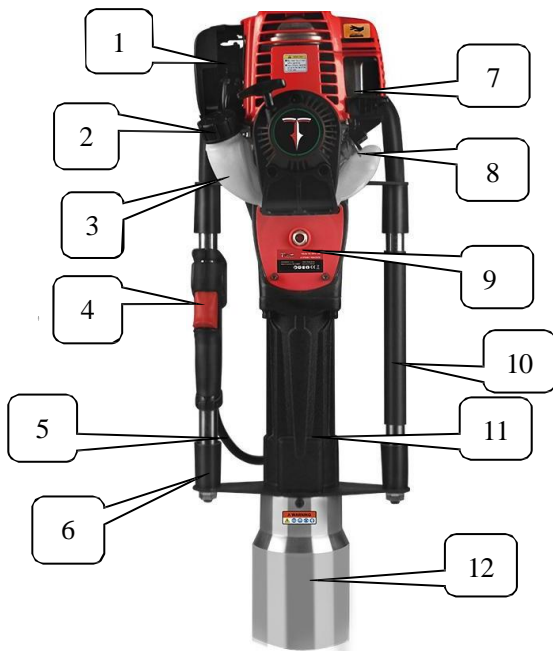

## **2. Description of Safe Operation**

1. The operator must wear slip-resistant safety shoes and suitable clothing. For long-time operation, he or she must wear a goggle, a helmet, and earplugs.
2. While operating the machine, please keep balance of the body, and stand in front of Air Filter to operate the machine. The operator shall not smoke, eat or chat while operating the machine.
3. After starting the machine, do not operate it with one hand.
4. When lifting the machine do not pull the throttle button, which will cause the machine to run at idle.
5. Non-staff shall be away from the operation area to avoid injuries.
6. Operate the pile driver at the medium speed.
7. Keep the handle dry and clean without greasy oil or fuel mixture.
8. If operation is stopped midway; be sure to turn off the engine.
9. Be sure to check whether fastening screws of the connector is tightened before use. If it's loose, it's necessary to tighten the screws before use.
10. Prohibit the use of pure gasoline fuel (no two-stroke oil), shall refer to Chapter 4.2 for recommended ratios of fuel.
11. Gasoline is highly flammable. Therefore, replenish fuel in a well-ventilated environment. During fuel filling, gasoline engine must be turned off.
12. Do not add too much oil. The oil shall not exceed the neck of oil filter of fuel tank. If fuel spills, start the machine after fuel on the machine volatilizes completely.
13. After refueling, tighten the oil lid. During work, check whether oil can is damaged and spills frequently. If damage is found, close down the machine immediately for replacement.
14. Reserve oil in storage areas. Remove hidden troubles of fire or open flame.
15. While the pile driver is used in closed areas such as tunnels, trenches and deep groove, it's necessary to guarantee normal air circulation to avoid waste gas poisoning and suffocation.
16. Forbid quick acceleration or braking so as not to damage the machine.
17. Before transport, empty fuel inside the fuel tank to avoid leakage.
18. Non-professional maintenance staff are prohibited from dismounting the pile driver to avoid structural damage of parts, shortened service life of the pile driver or accidents.

## **3. Main Use and Function**

### **3.1 Use: It can be used for outside piling operation of farms, orchard fences or barriers.**

### **3.2 Function**

- 3.2.1 It is the engine-type handheld gasoline pile driver which boasts light weight and low discharge capacity.
- 3.2.2 The product conforms to the design of man-machine engineering, reduces working strength of the operator to the greatest extent, and boasts simple and comfortable operation. The operator can achieve 360° all-around operation.
- 3.2.3 It can regulate impact energy and impact frequency and apply to a variety of piles below 120mm (inclusive) in diameter.
- 3.2.4 Advantage: Save the trouble of using heavy machines such as generator, air compressor and trucking-lorry.
- 3.2.5 The operating handle of the machine is rubber and plastic sponge handle which can greatly reduce the recoil force of the machine. It's installed with two-way damping spring which makes the user more comfortable.

## 4. Preparation before Use

### 4.1 Piling adapter and sleeve

4.1.1 Install Piling adapter of specifications of 120mm which are suitable for the pile size.

4.1.2 **Warning:** Pounding posts that are significantly smaller than the adaptor or sleeve will result in instability while using post driver. This may result in injury to the operator and will result in damage to Post Driver. Ensure there is minimum distance on either side of the post so it fits neatly in the barrel. Where there is too much clearance on each side, use a smaller sleeve.

### 4.2 Adding fuel

4.2.1 Use unleaded 90# gasoline or above.

4.2.2 When the gasoline engine is stopped, add fuel at well-ventilated areas away from open fire

4.2.3 If the engine is just operated, cool down to environmental temperature before adding oil.

4.2.3 Do not add too much oil. The oil shall not exceed the neck of the oil can. If fuel spills, wait until the fuel volatilizes completely and then start the machine.

4.2.4 Tighten the lid of oil can after refueling.

4.2.5 The machine uses pure gasoline as fuel.

### 4.3 Check and supply of engine oil

4.3.1 To avoid damage of the gasoline engine, before start, it's necessary to check whether the engine oil is adequate and needs replacement; for use of every 10 hours or that the gasoline engine has worked continuously for 10 hours, it's necessary to check liquid level of the engine oil and supplement engine oil to the upper limit of the oil tank.

4.3.2 The gasoline engine shall be placed horizontally. Unscrew the oil level gauge and check the oil liquid level as it's shown below. For inadequate oil, add to the upper limit. If oil is too dirty, replace it.

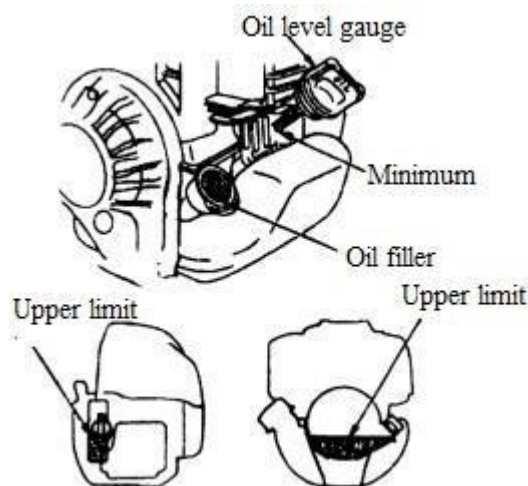

4.3.3 The recommended environmental temperature of the machine is -15°C-40°C. Recommend use of SAE 10W-30 engine oil which equals to API classification SE, SF, and SG.

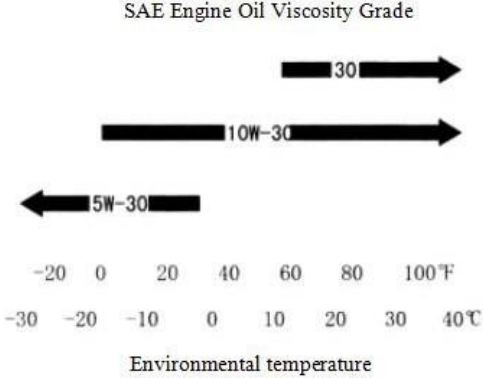

**4.4 Check of air filter**

- 4.4.1 Take apart the cover of the air filter, and check whether filter element is clean. If not, clean it.
- 4.4.2 After the check, correctly install the cover of the air filter to its normal position.

**5. Starting**

5.1. Before starting the machine, press the transparent and semi-circle fuel bubble repeatedly until the carburetor is filled with fuel. (Control Choke. To start cold engine, close the air door. Open air door after engine starts. To start warm engine, leave chock leave on open position to open air door. )



5.2. Control and operate the handle tightly with one hand while the other pulls the pulling handle of starter for over 50cm quickly. Do not let the pulling handle go back freely in repeated pulling but hold it tightly to avoid injury resulting from quick resilience.

5.3 Start the gasoline engine and then open air door completely. After idle operation of 5 minutes, start normal work.

5.4 Do not pull the handle of the starter during operation, since parts rotating with high speed may damage the starter.

### 6. Operation

6.1 After the gasoline engine is started, first carry out idle operation for 5 minutes to warm up the machine.

6.2 When the gasoline engine is warmed up, press throttle button to the appropriate regulatory position according to the required impact energy.

Note: The new gasoline pile driver use shall mainly boast low or medium-speed for work in the first 20 hours of operation and the maximum throttle shall not be used in order to extend the service life.

6.3. Operating speed of the gasoline engine shall be at medium speed.

**6.4. Do not press the throttle lever until the post driver is on a post.**

6.5. High-speed operation of pile driver during non-piling is prohibited.

6.6. Ensure the post is in a vertical position and the post driver is on in a parallel plane to the post. The correct position as below picture:

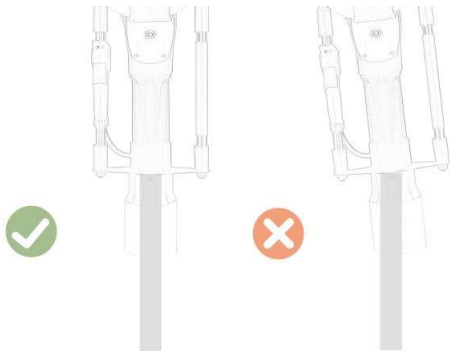

### 7. Turning off the Machine

7.1 Release throttle button and carry out idle running of the machine for 3-5 minutes.

7.2 Pull Stop Switch to the position of flameout. See the position of Stop Switch.



## 8. Technical Maintenance

### 8.1 Air Filter

Check air filter regularly. Soot deposit blocking filter element of air filter will reduce power of gasoline engine and service life. If the filter has too much soot deposit, clean it with warm water and detergent, and then wipe dry it with dry cloth, and then install the air filter. Filter should be replaced if damaged. Particularly if it's in the environment of much dust, maintenance cycle shall be shortened properly.

### 8.2 Fuel filter

If the fuel filter is blocked, the pile driver will have reduced speed and weaker impact energy. Method: ①Open the oil can lid. Get out the fuel filter from the oil can with metal hook and clean it. ②When cleaning the fuel filter, clean the oil can at the same time.



### 8.3 Carburetor

Oil can and carburetor generally have residual oil. After some time, the residual oil will become greasy oil which block up the oil line, causing that the engine can't be started. Therefore, when the machine is not used for more than one week, be sure to completely take the fuel out. Method: Pull out the oil inlet pipe, press the fuel bubble of the carburetor repeatedly for oil discharge, and press the oil inlet pipe back to its position when fuel in fuel bubble and oil return pipe is emptied.

### 8.4 Spark plug

To ensure normal operation of the engine, spark plug gap must be proper. Remove carbon sediment with a wire brush. Proper gap of spark plug is 0.5-0.7 mm.

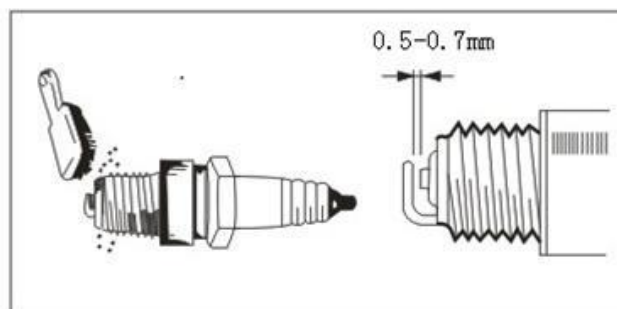



### 8.5 Muffler

Regularly remove dirt on inlet and outlet of the muffler, or clean dirt in it with detergent.

### 8.6 The cylinder cooling fin

Regularly remove dust to ensure the cylinder cooling. The gasoline pile driver is air-cooling type. If dust accumulates on the cylinder cooling fin, the cooling effect will be influenced directly, which will lead to failure of the cylinder.

### 8.7 Engine oil replacement

8.7.1 Inadequate cleanliness of the engine oil will lower the service life of the moving parts of the gasoline machine. Replace the engine oil regularly and keep adequate amount of engine oil in the gasoline machine.

8.7.2 Engine oil replacement cycle: replace engine oil after 10 hours in case of first use, and then replace engine oil every 6 months or after operating for 50 hours.

8.7.3 Dump the oil when heating the machine to ensure quick and thorough oil drainage.

8.7.4 Engine oil replacement steps:

- a. Make sure the oil can lid is tightened.
- b. Put a proper container beside the gasoline machine to hold the waste engine oil.
- c. Dismount the oil level gauge, lean the engine towards the oil filler and dump the engine oil into the container.



d. Place the gasoline machine horizontally and add the recommended engine oil to the bottom edge of the oil filler. For the additive amount of engine oil, refer to Fig. 3 in the above steps.

e. There is still some residual engine oil after oil drainage. Add new engine oil after the residual oil is below 100mL. Add oil slowly to the bottom edge of the oil filler.

8.7.5 The recommended environmental temperature of the machine is  $-15^{\circ}\text{C}$ - $40^{\circ}\text{C}$ . Recommend use of SAE 10W-30 engine oil which equals to API classification SE, SF, and SG.

8.8 Filling of impact cylinder lubrication

After working for an accumulated 50 hours, fill special lubrication of 50g for the impact cylinder.



Lubrication hole



## 9. Failure Analysis and Its Eliminating Methods

### Problem analysis and solving

#### Example 1: Difficulties in starting engine in cooling state

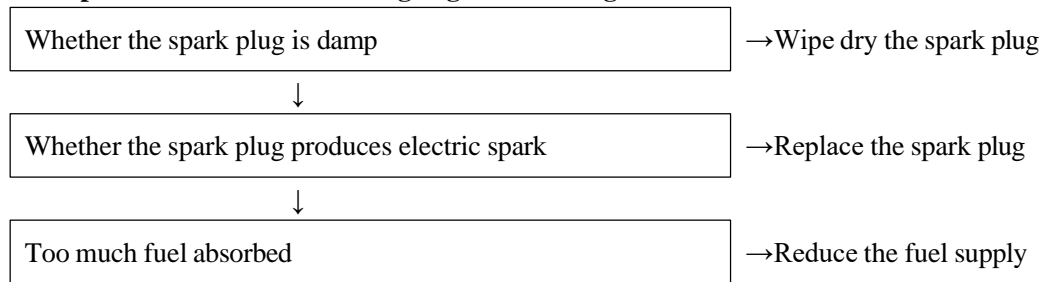

#### Example 2: Difficulties in restarting after a sudden stop

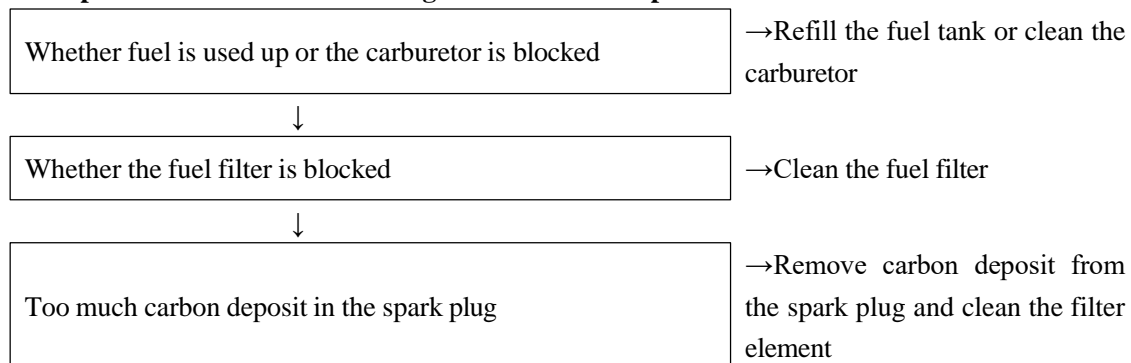

#### Example 3: Slow speed and weak power

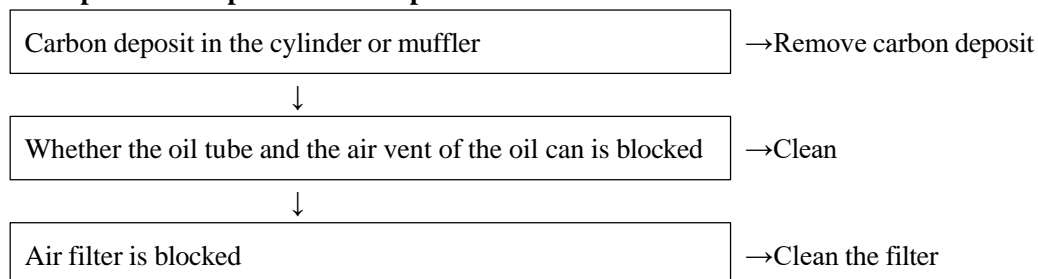

#### Example 4: Abnormal sound

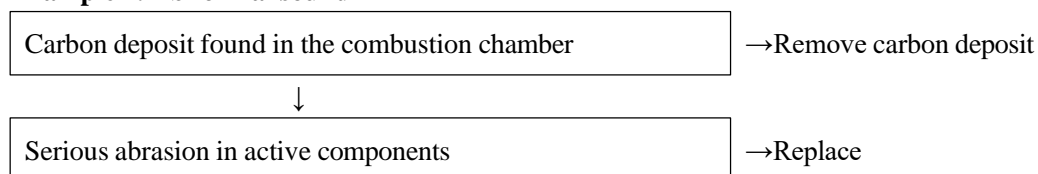

#### Example 5: The machine is working normally but the work efficiency is very low

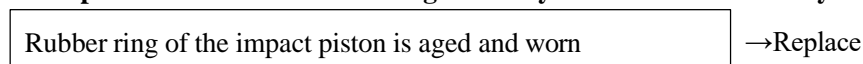

Please contact with local sales agent or contractual maintenance site for maintenance.

## 10. Key Data of Product

Gasoline engine type	140FA single cylinder, air cooling, 4-stroke
Model	PRPD120
L×W×H (mm)	831x292x324
Fuel	Unleaded gasoline 90# or above
Oil level	0.08L
Oil can capacity	0.58L
N.W/G.W	22.7KG/34KG
Displacement	37.7CC
Max power and rotate speed	0.87kw / 6500 r/min
Max torque and rotate speed	1.63N.m/5500r/min
Fuel consumption rate	≤480g/kW.h
Impact frequency	900-1300BPM
Impact energy	25-50 J
Carburetor type	H129-1C7
Spark plug type	CMR5H
Starter system	Hand pull start
<b>**Storage post driver in vertical position in case the engine oil infiltrate into combustion chamber and cause damage to the engine.</b>	

## 11. Declaration of Conformity

We declare under our sole responsibility that our post driver confirm with following standards EN ISO 12100:2010, EN61000-6-1:2007, EN 61000-6-3:2007+A1:2011 or standardization documents: in accordance to the regulation of directives 2006/42/EC, 2014/30/EU.

## 12. Maintenance Cycle

The following data are given from the common use of the product. Under worse working conditions such as dusty environment or long work hours of the gasoline-powered wrench, the maintenance cycle should be shortened correspondingly.		Before work	After work or every day	After Filling oil	Every Week	Every Month	Temporary Failure	If necessary
The whole machine	Outlook check (state, tightness of screws)	√		√				
	Clean		√					
Control handle/stop button	Function check	√		√				
Air filter	Clean				√			√
	Replace						√	
Fuel filter	Check					√		
	Replace						√	
Oil can/Oil can lid	Clean		√	√				
	Check	√		√				
	Tighten							√
Reduction gearbox/impact cylinder	Clean					√		
	Add grease							√
Muffler	Check					√		
	Remove carbon deposit							√
Cylinder cooling fin	Check					√		
	Clean							√
Spark plug	Check/Adjust the distance between electrodes					√		
	Replace							√
Screw and nut	Check	√		√				
	Tighten							√

### 13. Parts List and Exploded View of DPD-120 Pile Driver

No.	Description	Qty	No.	Description	Qty
101	Adapter 120mm	1	139	Circlip for hole	1
102	Ø8 Flat gasket	8	140	Bearing 6203	2
103	Ø8 spring washer	20	141	Mid gear	1
104	M8X20 Hexagon screw	4	142	Mid axle	1
105	Impact hammer	1	143	Axis	1
106	M8X55 Hexagon screw	6	144	Spacer	1
107	Metal head	1	145	M6*25 Hex cylinder head spring pad assy	6
109	Punch hammer	1	146	Upper support plate	1
110	Switch block	1	147	Lifting yoke	1
111	Tubular handle	1	150	Gear box	1
112	Under support plate	1	151	M6*20 Hexagonal cylinder screw	1
113	M14 flange screw nut	2	152	Bearing 6205	1
115	Big tendon seal	1	153	Eccentric shaft	1
116	O-ring ( 23.6*5)	1	154	Straight pin	1
117	Shank adapter	1	155	Connection rod	1
118	Gasket for cylinder(59*69-2)	3	156	Needle bearing 18/20	1
119	Cover for broken ring	1	157	Clip board for connection rod	1
120	Broken ring	1	158	M8*16 Flange hexagon screw	1
121	Small tendon ring	1	159	ST4*12 tapping screw	6
122	M8X45 Hexagon socket head screw	4	160	Wick	1
123	Front placket	1	161	One-way valve	1
124	Cylinder	1	162	Inside cover for tank	1
125	Double lip ring	1	163	O-ring 2.65*75	1
126	Piston	1	165	Outside cover for tank	1
127	Paper washer for front placket	1	164	T-type seal ring	1
128	Handle	1	166	leather collar for oil leveler	1
129	Damping spring	4	167	Oil leveler	1
130	Cover for spring	4	168	Bearing 6202	1
131	Bearing 6204	1	170	Clutch Drum for 4-stroke engine	1
132	Gland	1	171	Petrol engine	1
133	M5*12 sunk screw	4	172	Limitation washer	1
134	Big gear	1	173	Ø6 Flat gasket	6
135	Guard circle	1	174	6*27 straight pin	2
136	Gear box cover	1	175	Aluminum spacer for 4-stroke engine	1
137	M5*18Hexagonal cylinder head spring pad assembly	10	176	M6*50 Hexagonal cylinder screw	4
138	Shaft ring 17	1	177	Flat pad 6*12-2	4

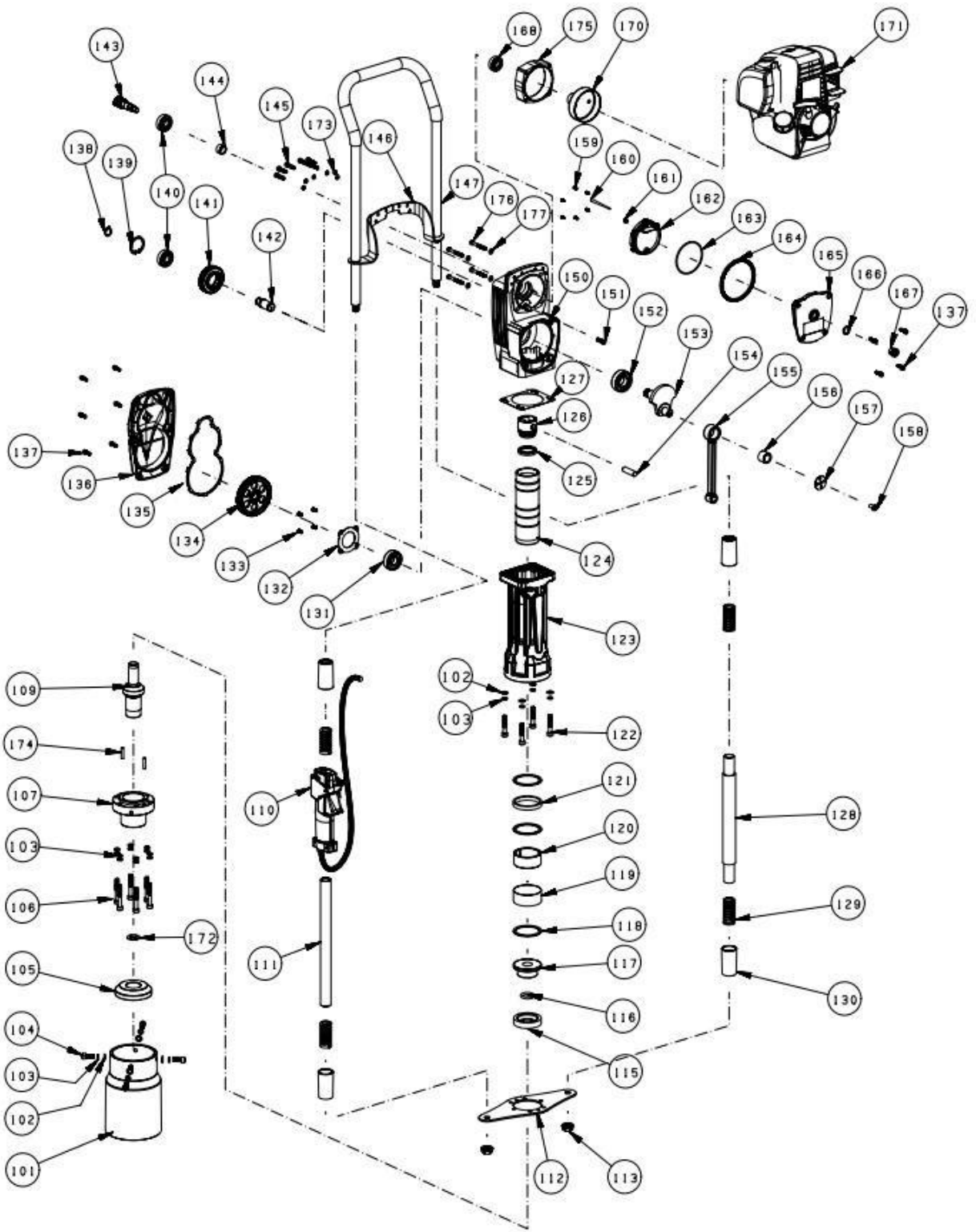

## 14. Parts List and Exploded View of 140FA

No.	Description
1	Flange screw M5X15
2	Cylinder cover
3	Flange screw M5×12
4	Air valve cover
5	oil-gas separator
6	Cylinder cover group
7	Bolt unit M4X8
8	Seal ring
9	Seal ring for valve cover
10	Air valve spring plate
11	Air valve spring
12	Exhaust rocker set
13	Air inflow rocker set
14	Rocker pin
15	Exhaust rocker block
16	Air inflow rocker block
17	Synchronous belt
18	Cam gear
19	Cam pin
20	Start driving plate
21	Starter
22	Flat gasket for inlet pipe
23	Small snap ring
24	Silencer guard
25	Flange nut M5
26	Bolt combination M5X55
27	Silencer
28	Muffler baffle
29	Sparking plug
30	Cylinder
31	High-voltage cable clamp
32	Stator

33	Bolt combination M4X14
34	Stop line
35	Exhaust valve
36	Intake valve
37	Balance air pipe
38	Small snap ring (A)
39	Seal ring for intake tube
40	Bolt M5X55
41	Part for intake pipe
42	Exhaust pipe
43	Carburetor mat
44	Carburetor
45	Filter inner cover set
46	Flange screw M5X22
47	Filter
48	Filter outer cover
49	Piston ring set
50	Piston ring set second
51	Doctor blade
52	Cushion spring
53	Piston
54	Crankshaft assembly
55	Gudgeon pin
56	Pinion oil seal
57	Oil level indicator
58	O-ring 14X2.65
59	woodruff key 3X5X13
60	Big oil seal
61	Spring set
62	Rotor
63	Nut M8
64	Gasket B
65	Tight block combination
66	Wave washer
67	Screw axle
68	Pin B4X8
69	Motor cover



70	Crankcase below
71	Flange screw M5X32
72	Fuel tank cap
73	Admission piece
74	Inner tank cover
75	End cover
76	Gland
77	Rubber bumper Block
78	Fuel tank
79	Tubing stopper
80	Oil return pipe
81	Oil inlet tube
82	Fuel filter
83	Piston pin retainer

