

M18FCHS-121B M18 FUEL™ CHAINSAW

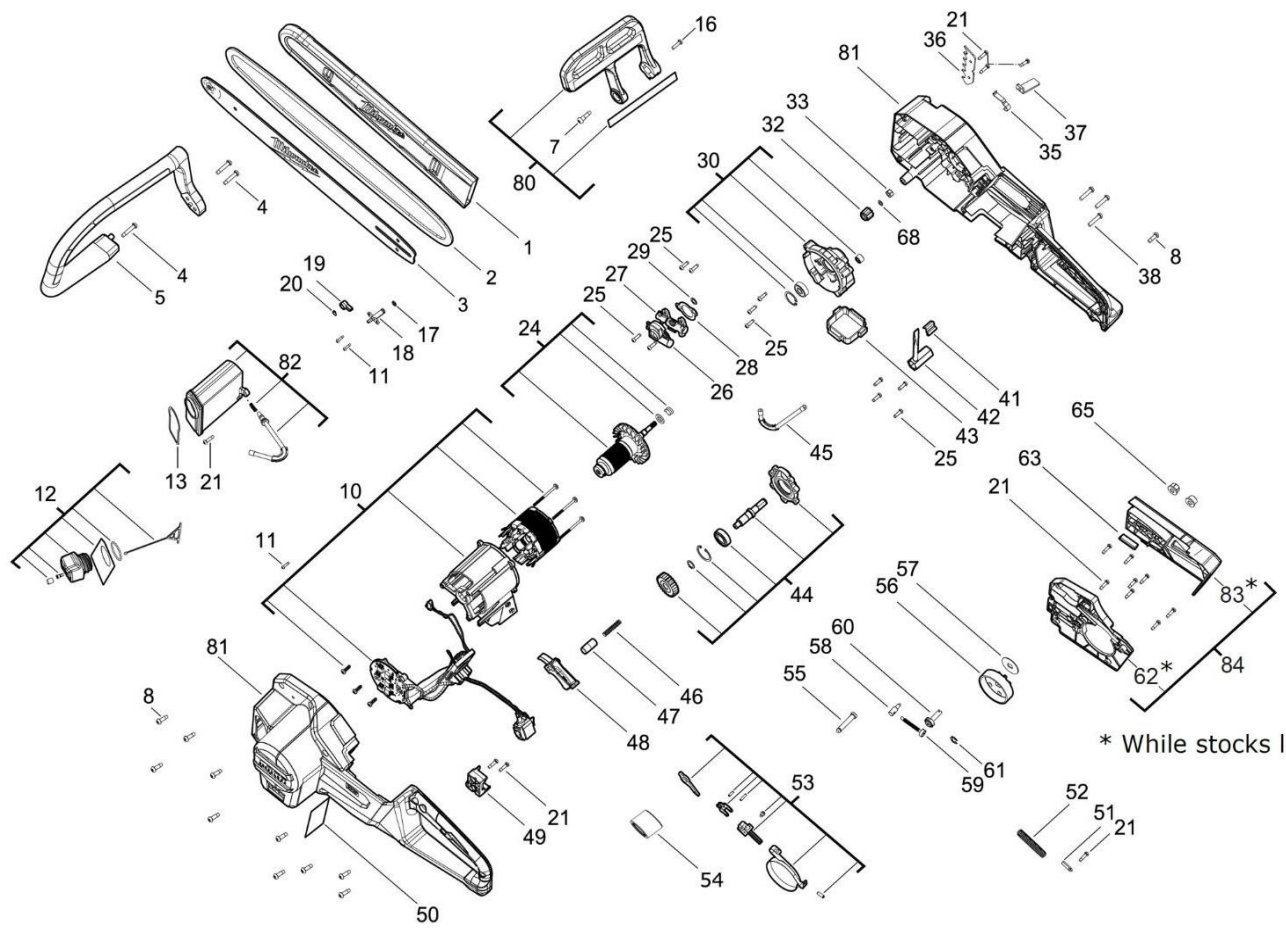



* While stocks last

Position	Quantity	Description	Part number
0001	1	GUARD	4931465906
0003	1	CHAINSAW SWORD	4932480174
0004	3	SCREW	4931454838
0005	1	HANDLE	4931465907
0007	1	SCREW	4931465908
0008	11	SCREW	4931465909
0010	1	ELECTRONIC	4931465910
0011	3	SCREW	4931436686
0012	1	CAP	4931465911
0013	1	SEAL RING	4931465912
0016	1	SCREW	4931465913
0017	1	O-RING	4931465914
0018	1	CONNECTOR	4931465915
0019	1	SWITCH	4931465916
0020	1	HOLDING RING	4931465917
0021	15	SCREW	660024030
0024	1	ROTOR	4931465918
0025	11	SCREW	4931435150
0026	1	DUST CAP	4931465919
0027	1	OIL PUMP	4931465920
0028	1	SEAL	4931465921
0029	1	WASHER	4931465922
0030	1	GEAR BOX	4931465923
0032	1	PINION	4931465924
0033	1	NUT	4931465925
0035	1	SPRING	4931465926
0036	1	WASHER	4931465927
0037	1	CORE LIFTER RING	4931465928
0038	3	SCREW	4931465929
0041	1	WRENCH	4931465930
0042	1	WRENCH	4931465931
0043	1	WIRE STRAP	4931465932
0044	1	GEAR BOX COVER	4931465933
0045	1	WIRE	4931465934
0046	1	SPRING	4931465935
0047	1	BUTTON	4931465936
0048	1	TRIGGER	4931465937
0049	1	SWITCH RETAINER	4931465938
0050	1	RATING PLATE	4931465939
0051	1	RETAINING PLATE	4931465940
0052	1	SPRING	4931465941
0053	1	STOP WASHER	4931465942
0054	1	BUSH	4931465943
0055	1	BOLT	4931465944
0056	1	DRIVING ROLL	4931465945
0057	1	WASHER	4931465946
0058	1	SCREW	4931465947
0059	1	SCREW	4931465948
0060	1	SCREW	4931465949
0061	1	SLEEVE	4931436401
0062	1	COVER	4931472746
0063	1	BRACKET	4931494478
0065	2	NUT	4931465951

0068	1	WASHER	4931465952
0080	1	HANDLE	4931465953
0081	1	HOUSING	4931465954
0082	1	TANK	4931465955
0083	1	COVER	Item discontinued -4931465956
0084	1	COVER	4931494479